

Prospects for CO₂-reduction in transport : Hydrogen or electric vehicles

Amela Ajanovic
Energy Economics Group
Vienna University of Technology

- Introduction
- Policy framework
- Electric vehicles
 - Economic assessment
 - Environmental assessment
- COVID-19
- Conclusion

- oil products
- least-diversified
- energy import dependency

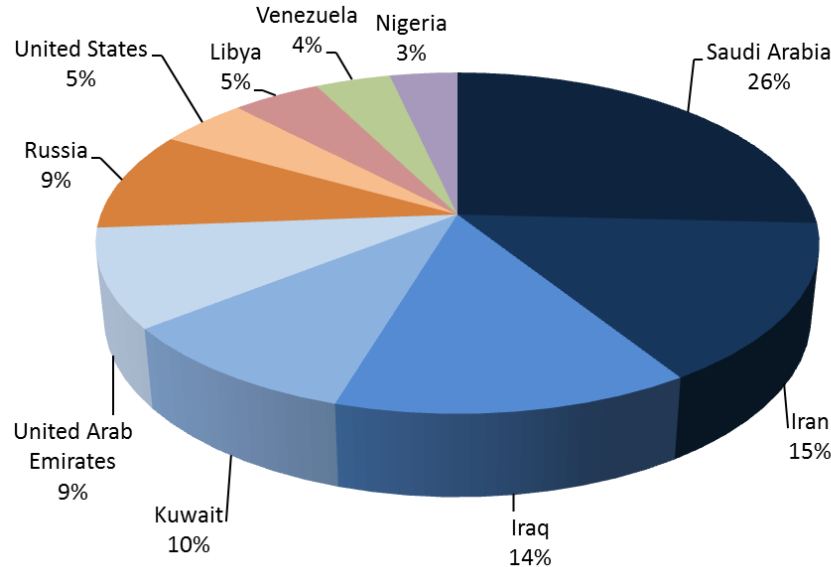

Countries with largest conventional oil reserves

Greenhouse Gas Emissions (GHG) by Sector: EU-28

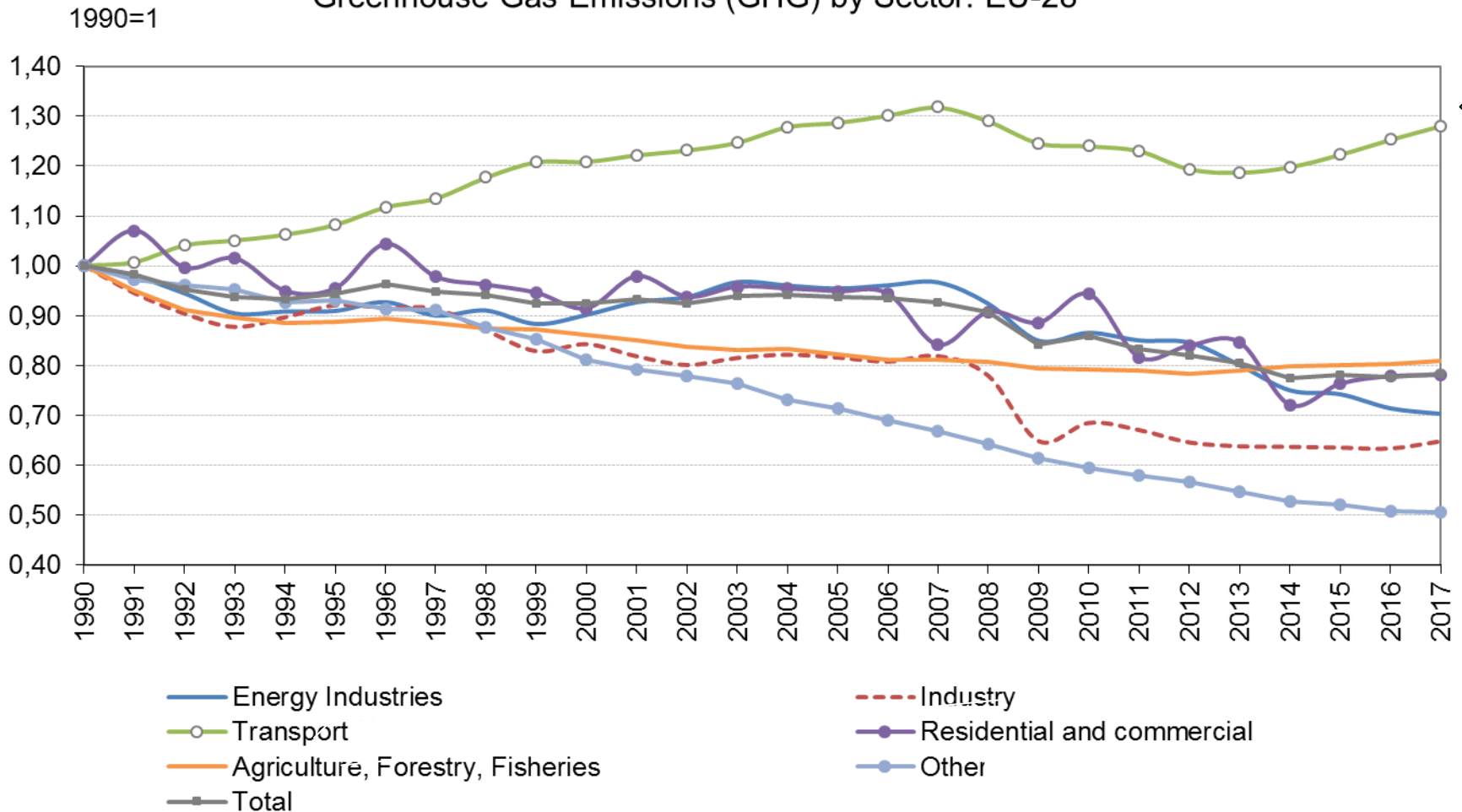

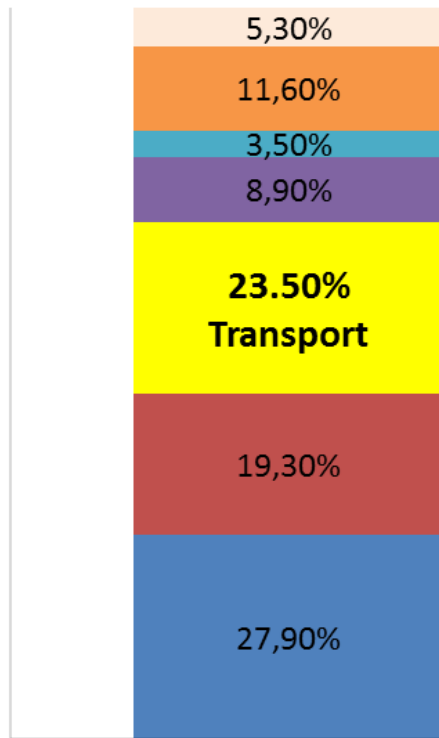

ALL SECTORS

- Energy industries
- Industry
- Transport
- Residential
- Commercial/institutional
- Agriculture, forest, fisheries
- Other sectors
- Road transportation
- Other transport modes
- Cars
- Other transport means

Climate & energy package

GHG: **20** - RES: **20** - EE: **20**

GHG: **40** - RES: **32** - EE: **32.5**

TRA: **10%**

TRA: **14%**

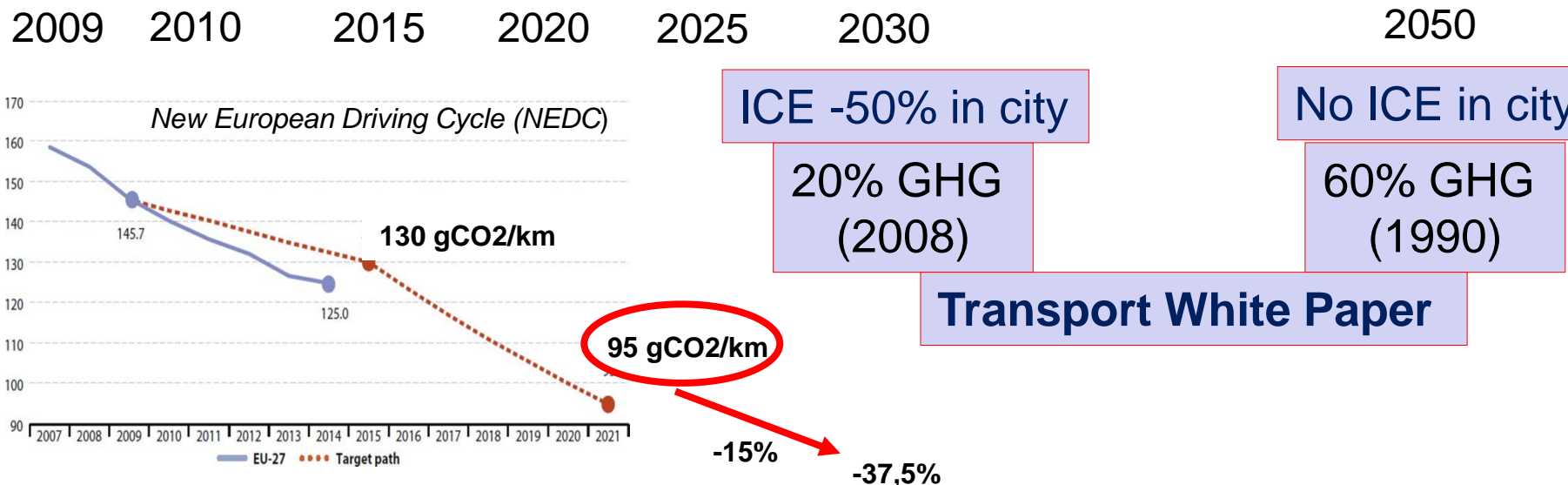

Targets and average CO₂ emissions from new passenger cars in EU countries

World harmonized light-duty vehicles test procedure (WLTP)

Announced 100% ZEV sales targets and bans on ICE vehicle sales

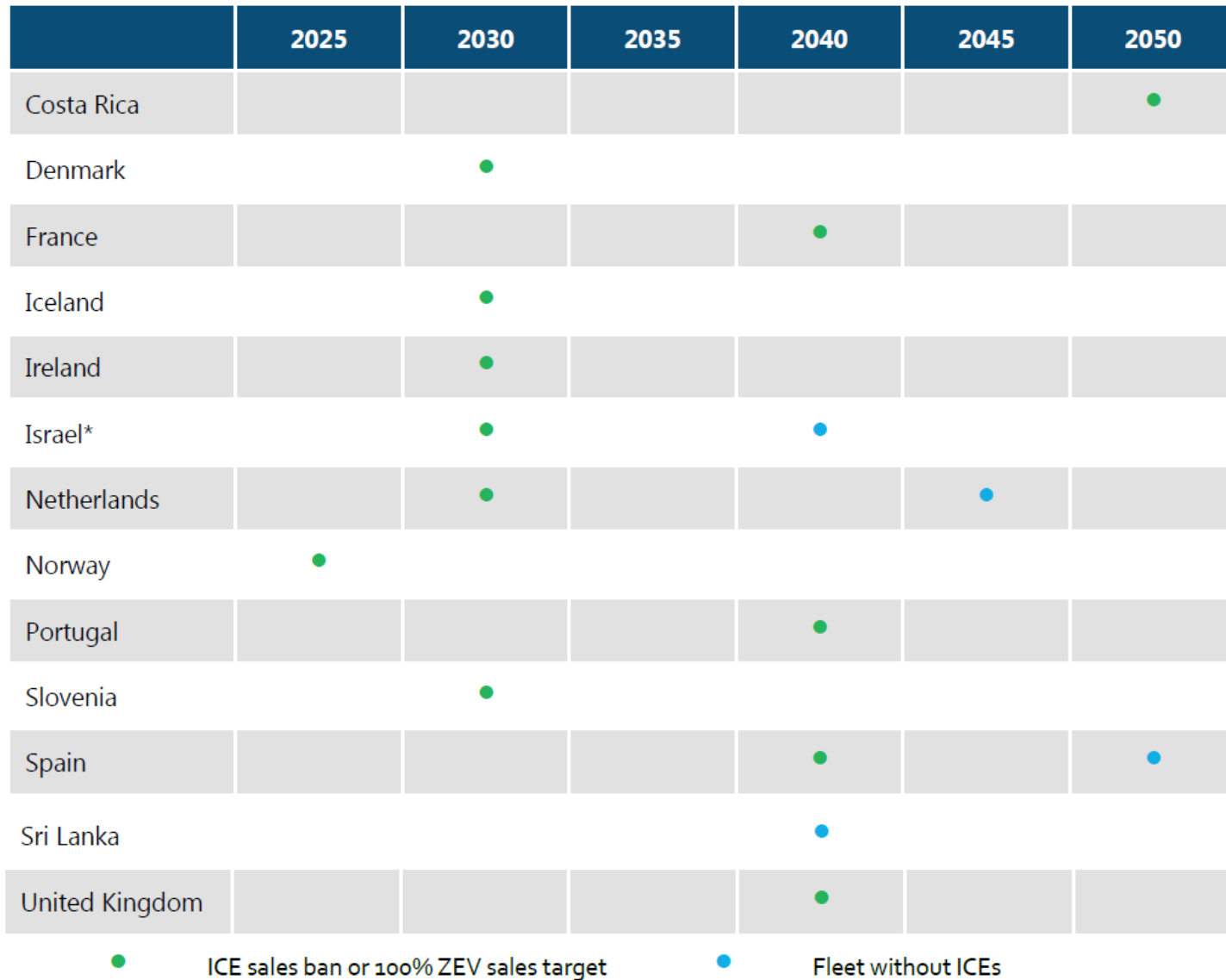

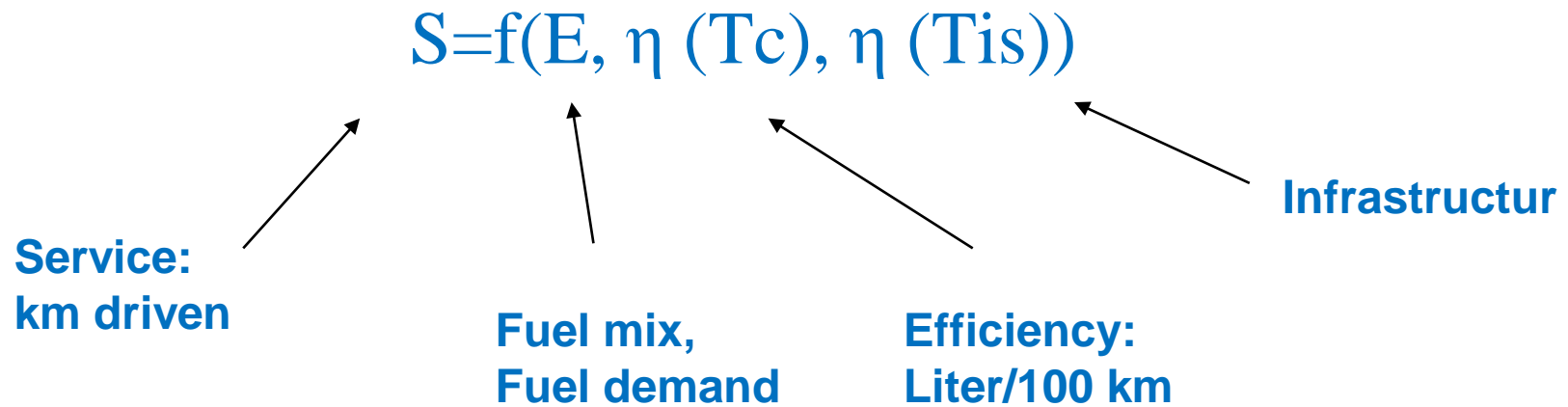

Paris Declaration on Electro-Mobility and Climate Change & Call to Action:

- more than 100 million EVs
- 400 million two and three-wheelers

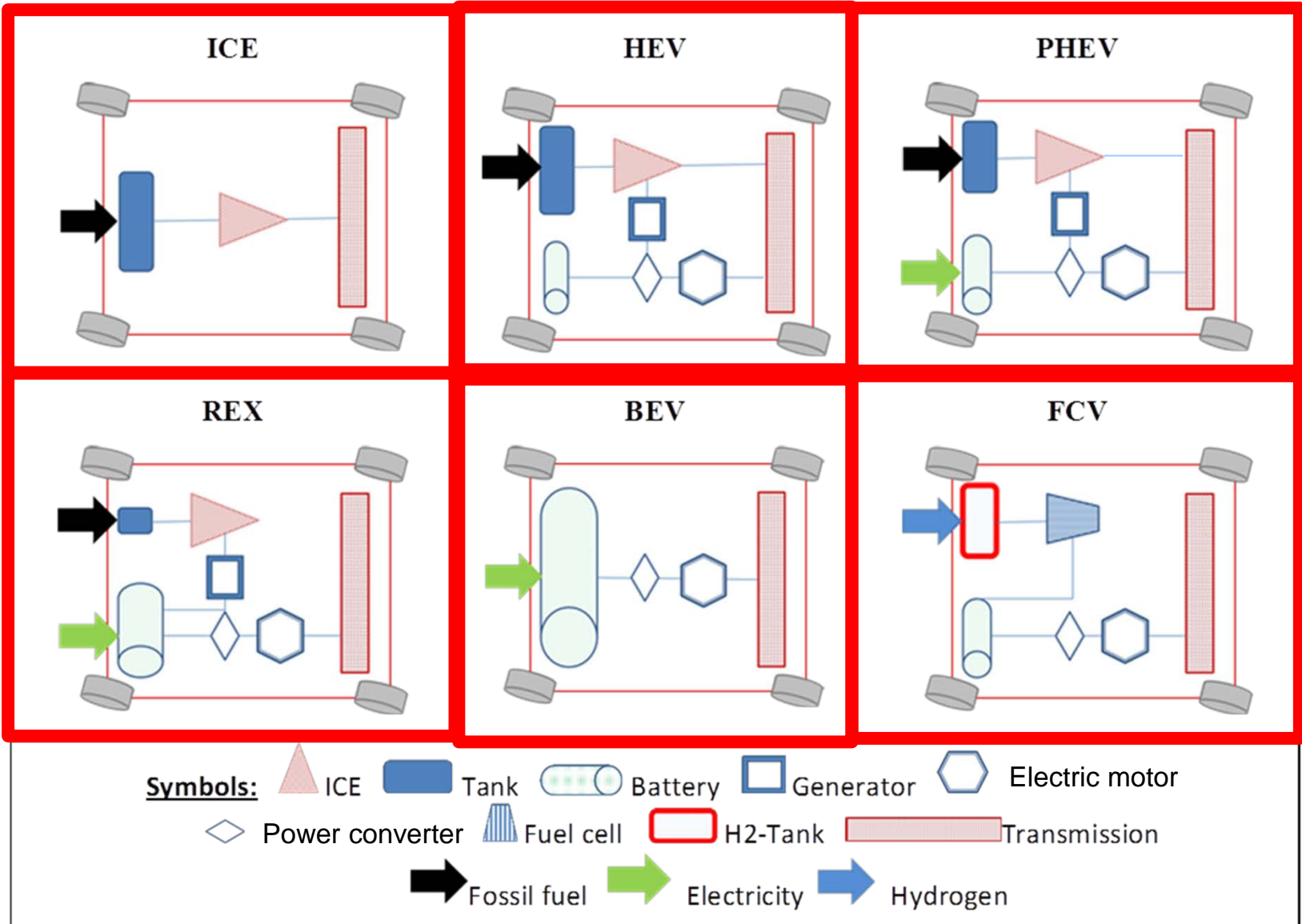

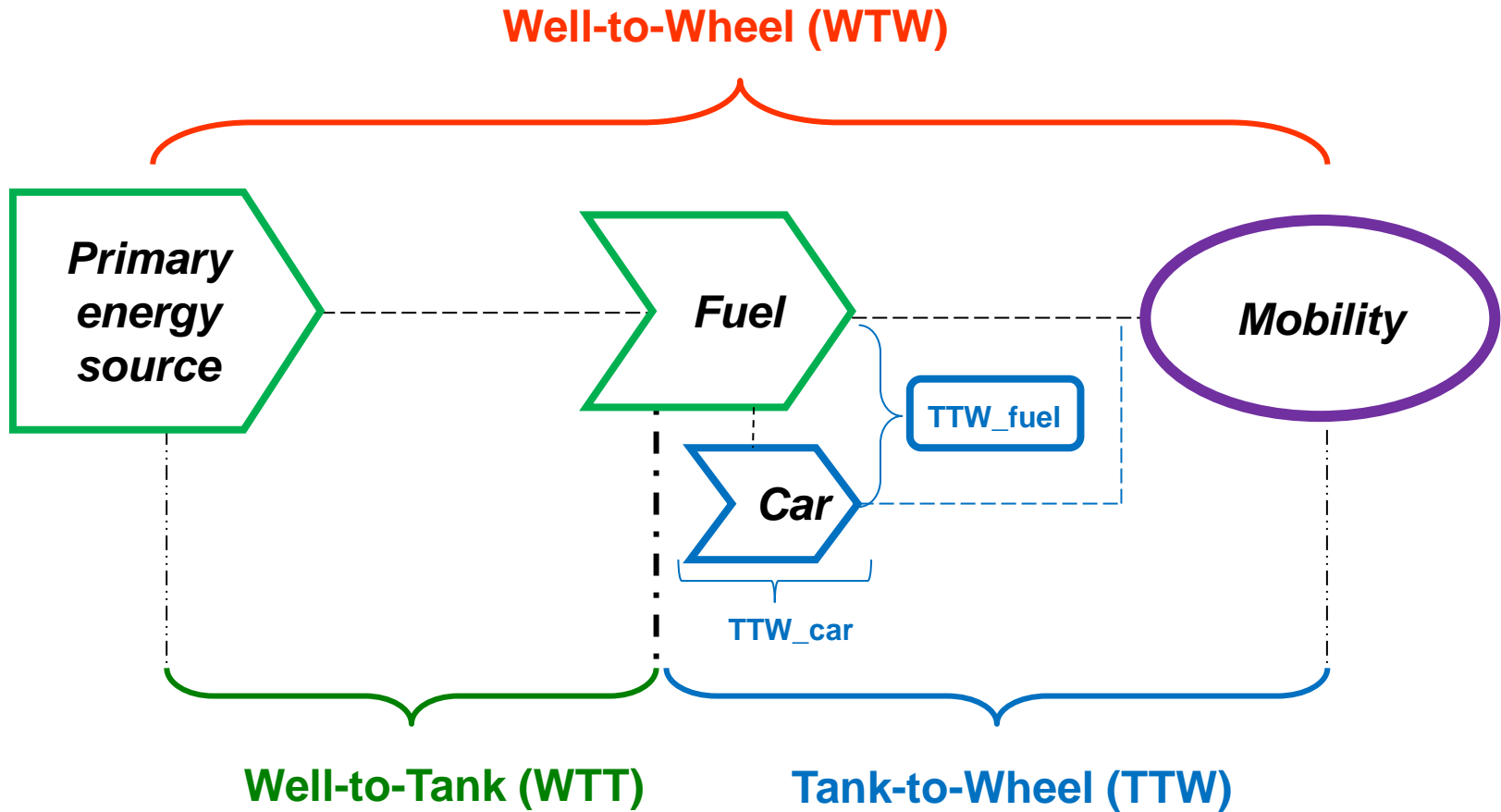

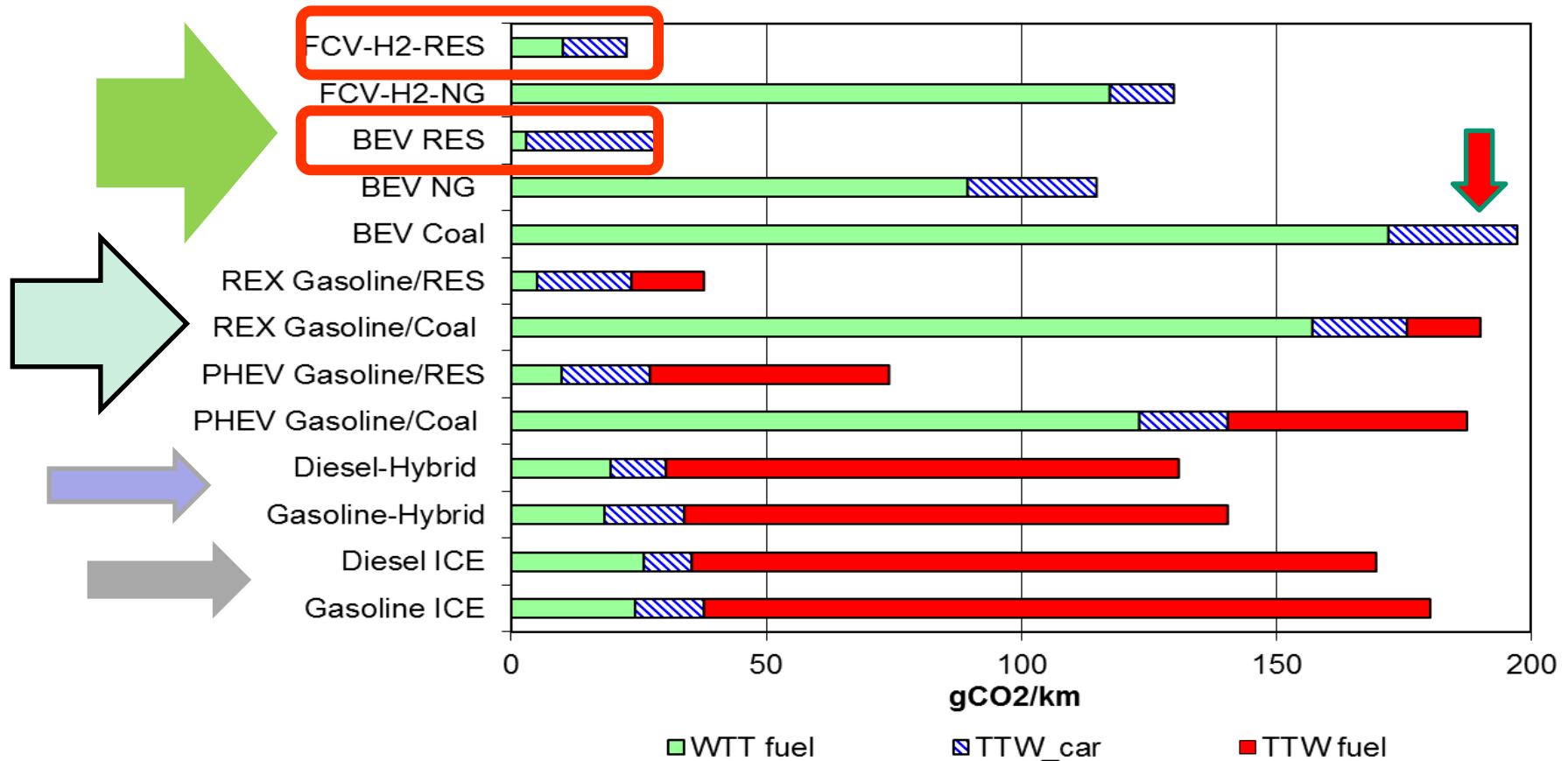

CO₂ emissions per km driven for various types of EV in comparison to conventional cars (power of car: 80kW)

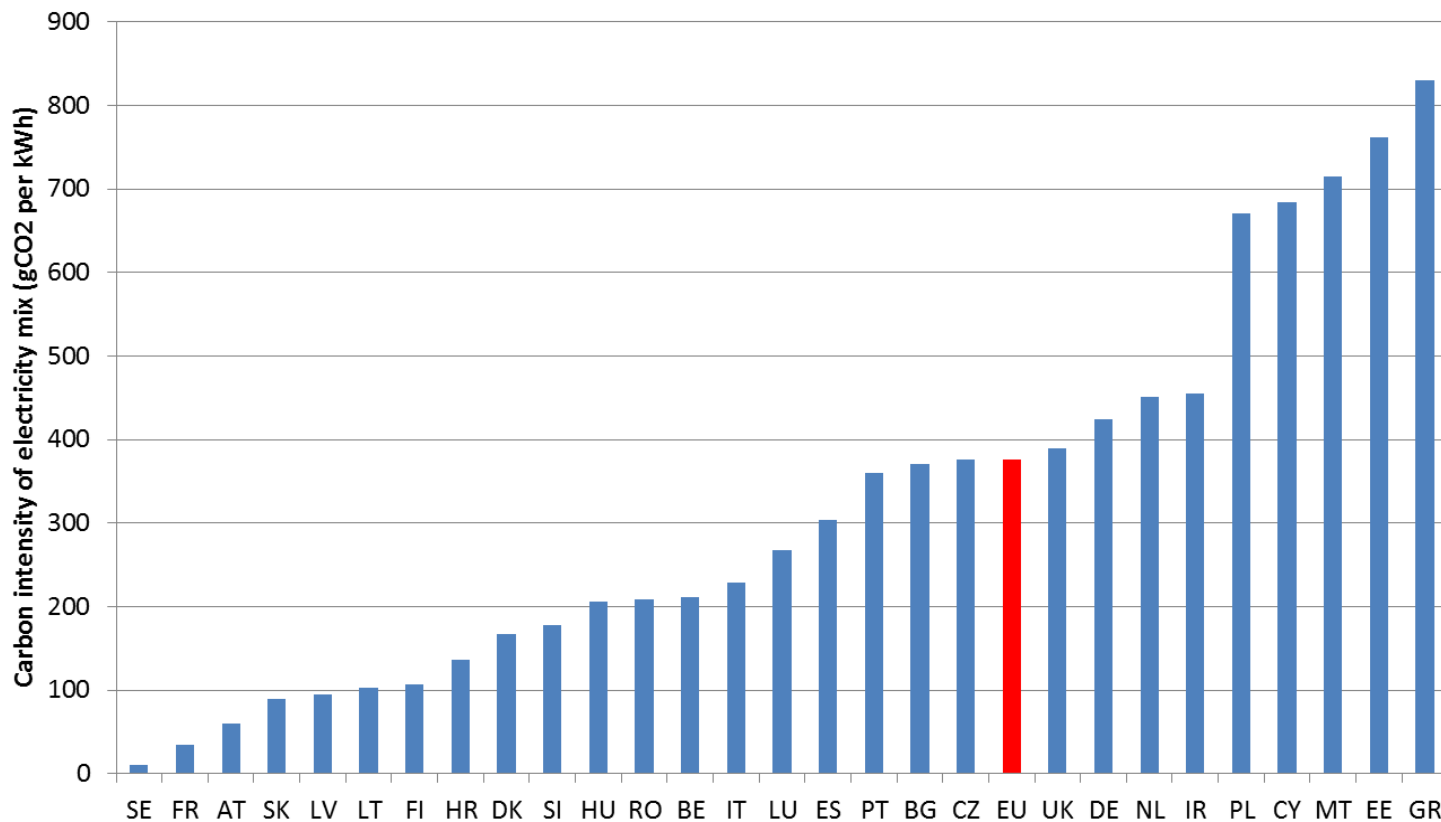

CO2 per kWh electricity generated in different European countries

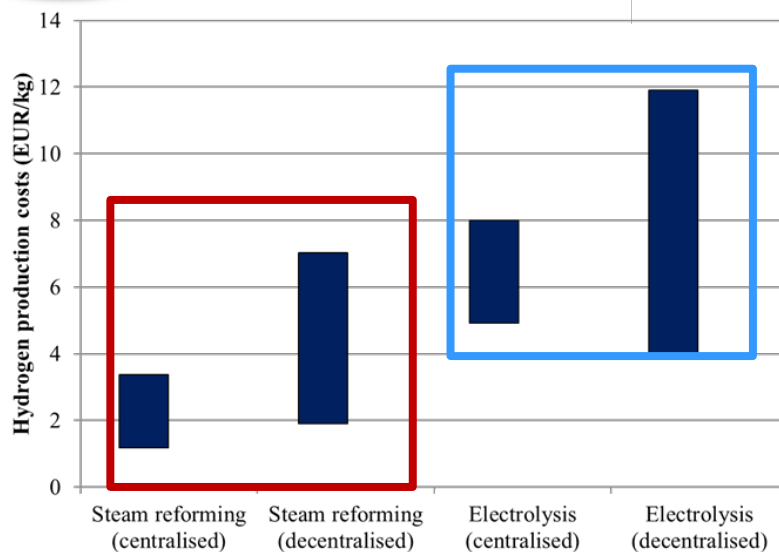
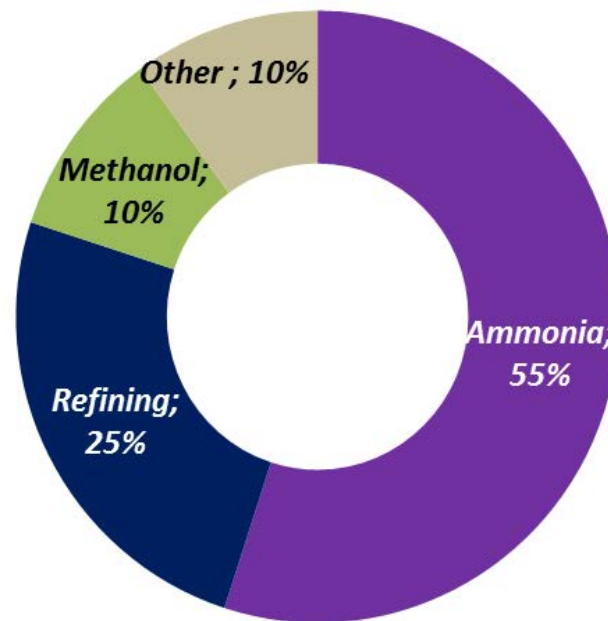
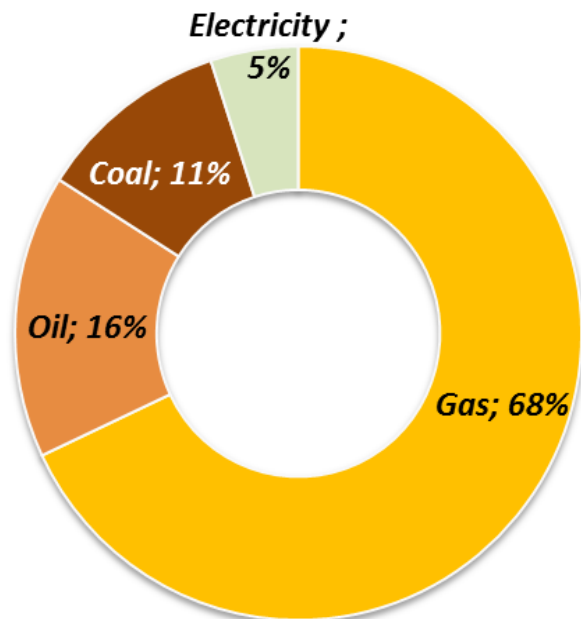

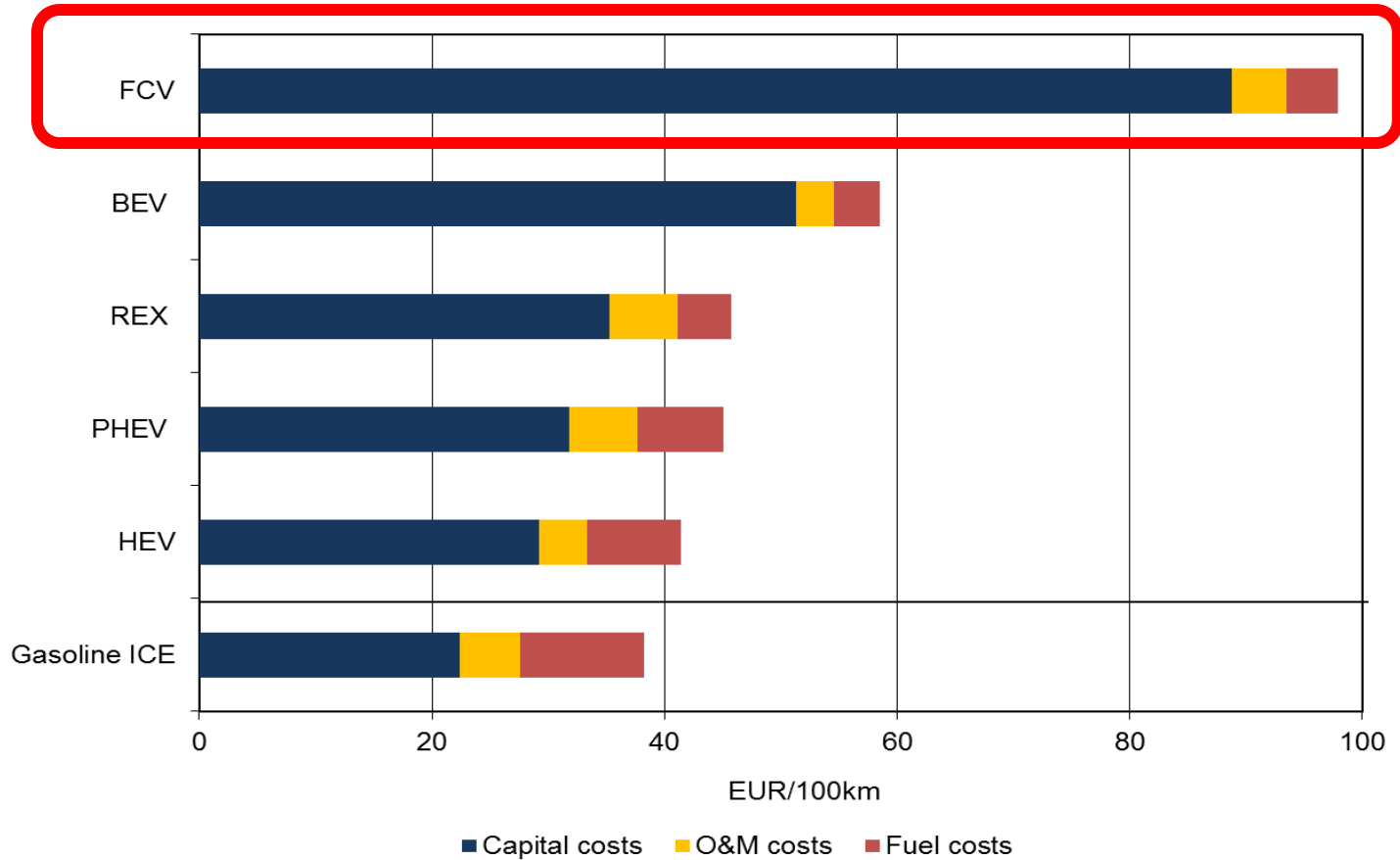

Total costs of service mobility of various types of EV in comparison to ICE cars

Fuel cell vehicles

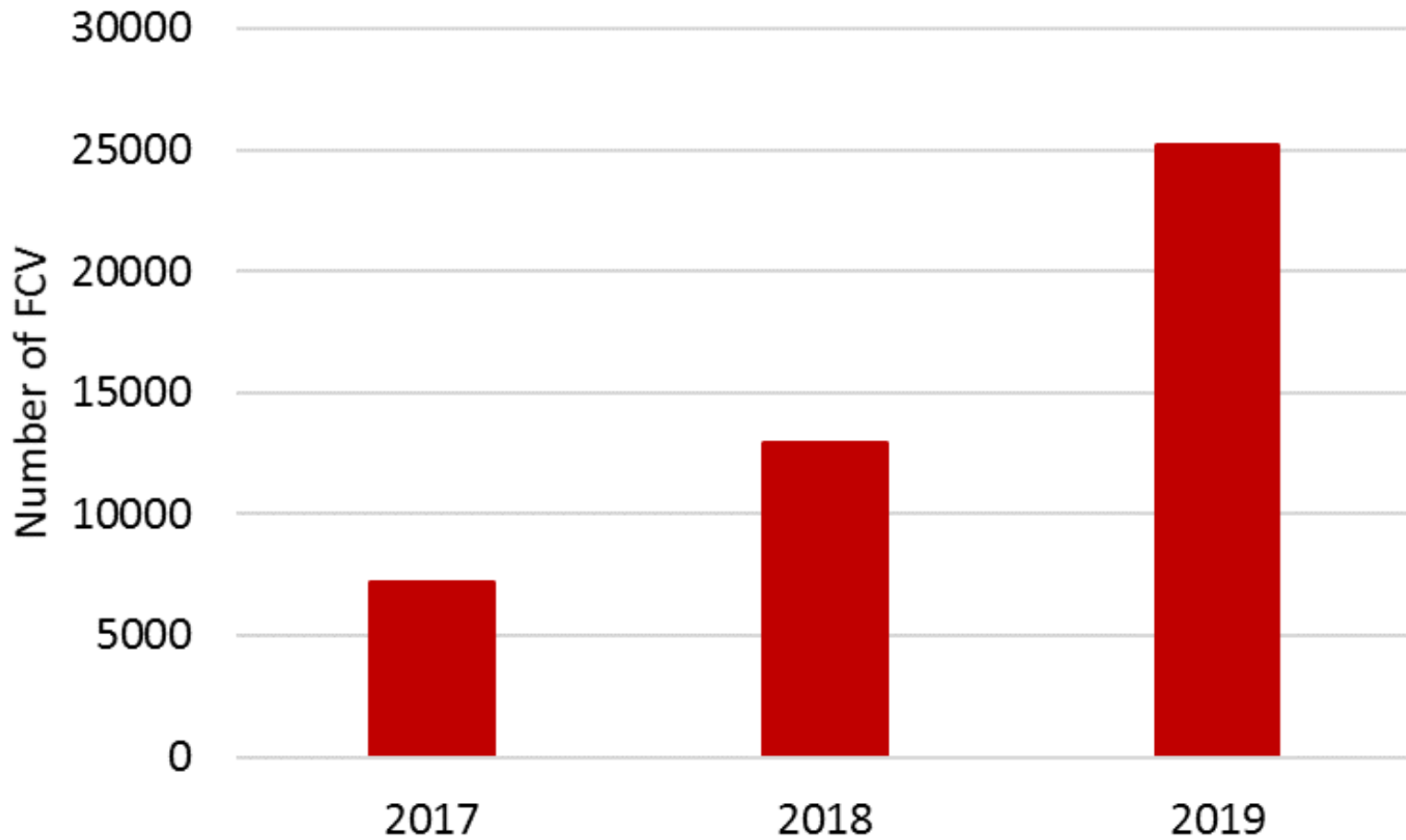

Fuel cell vehicles

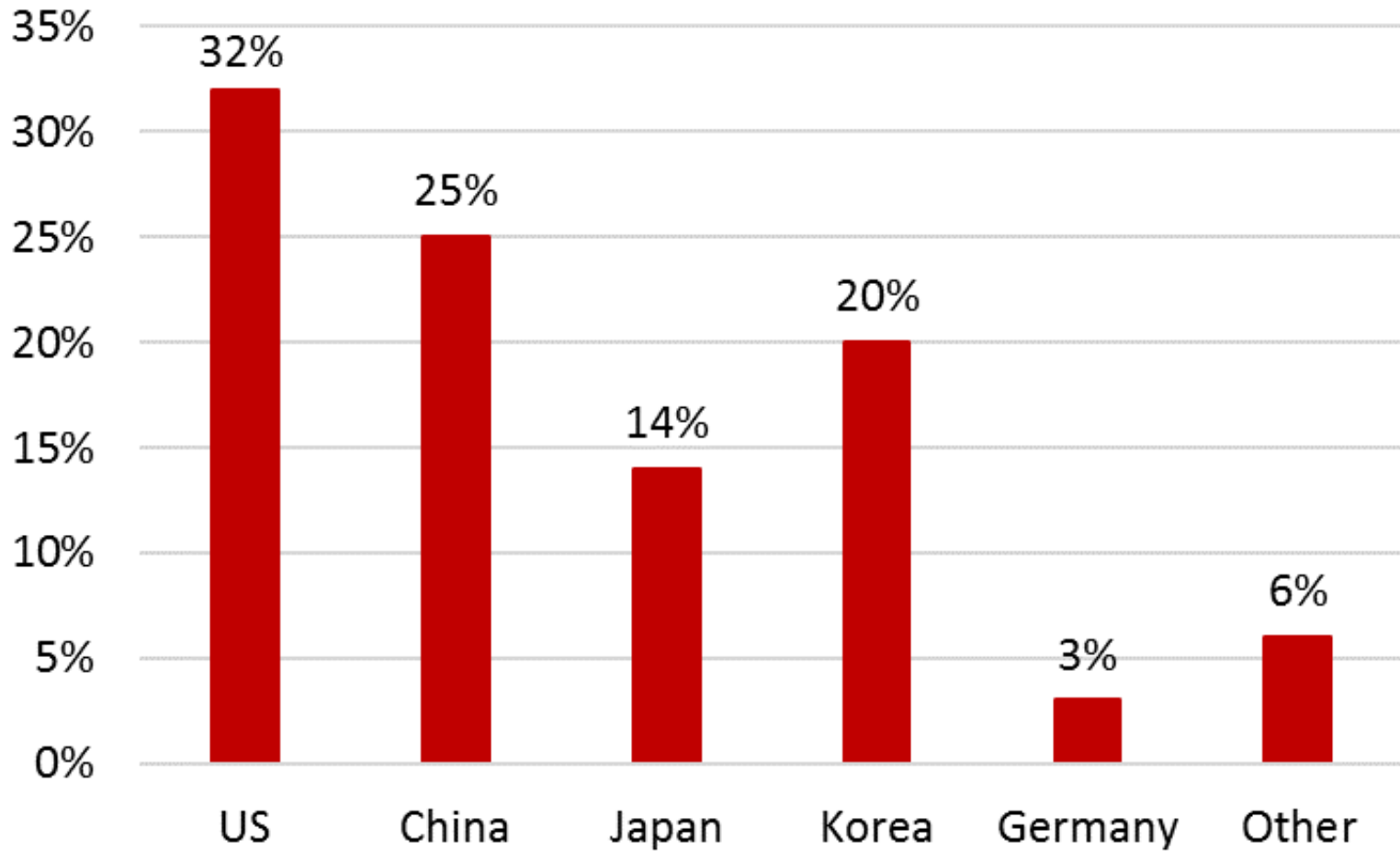

Hydrogen refueling stations

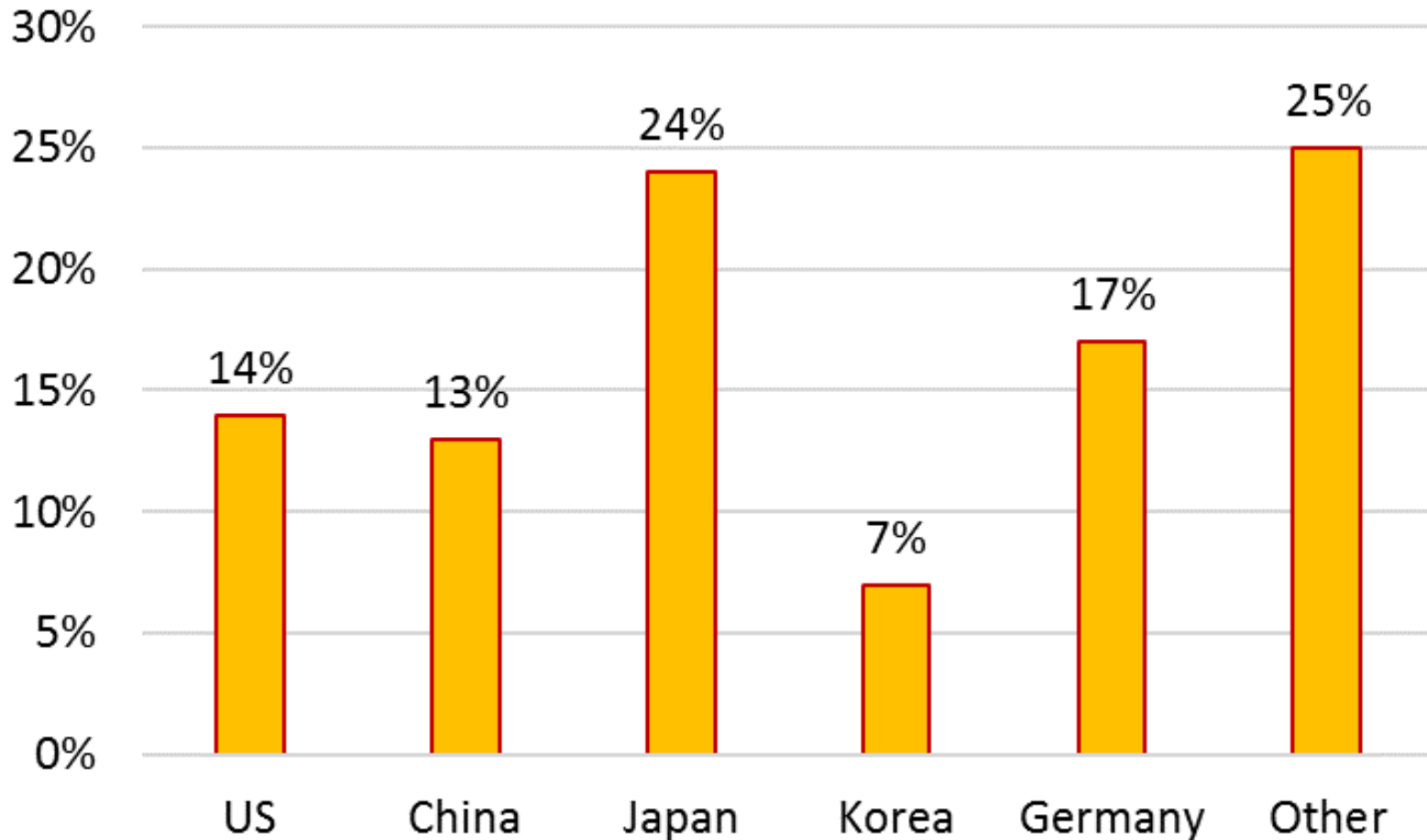



Global stock of rechargeable EVs

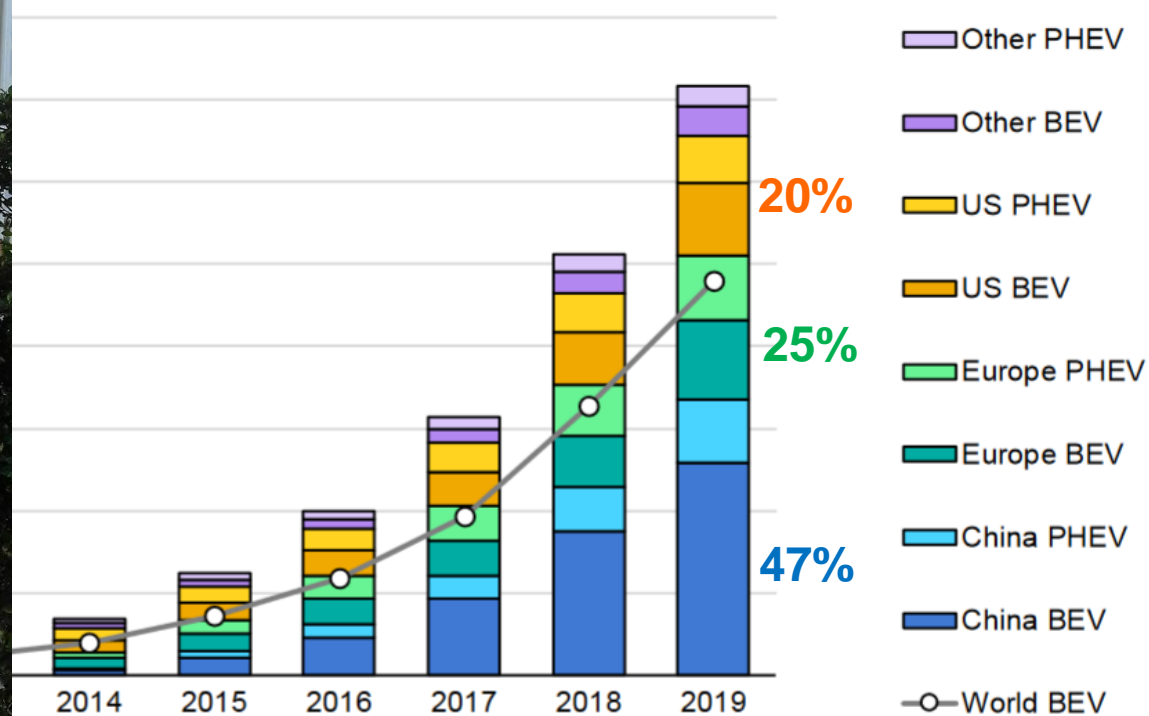

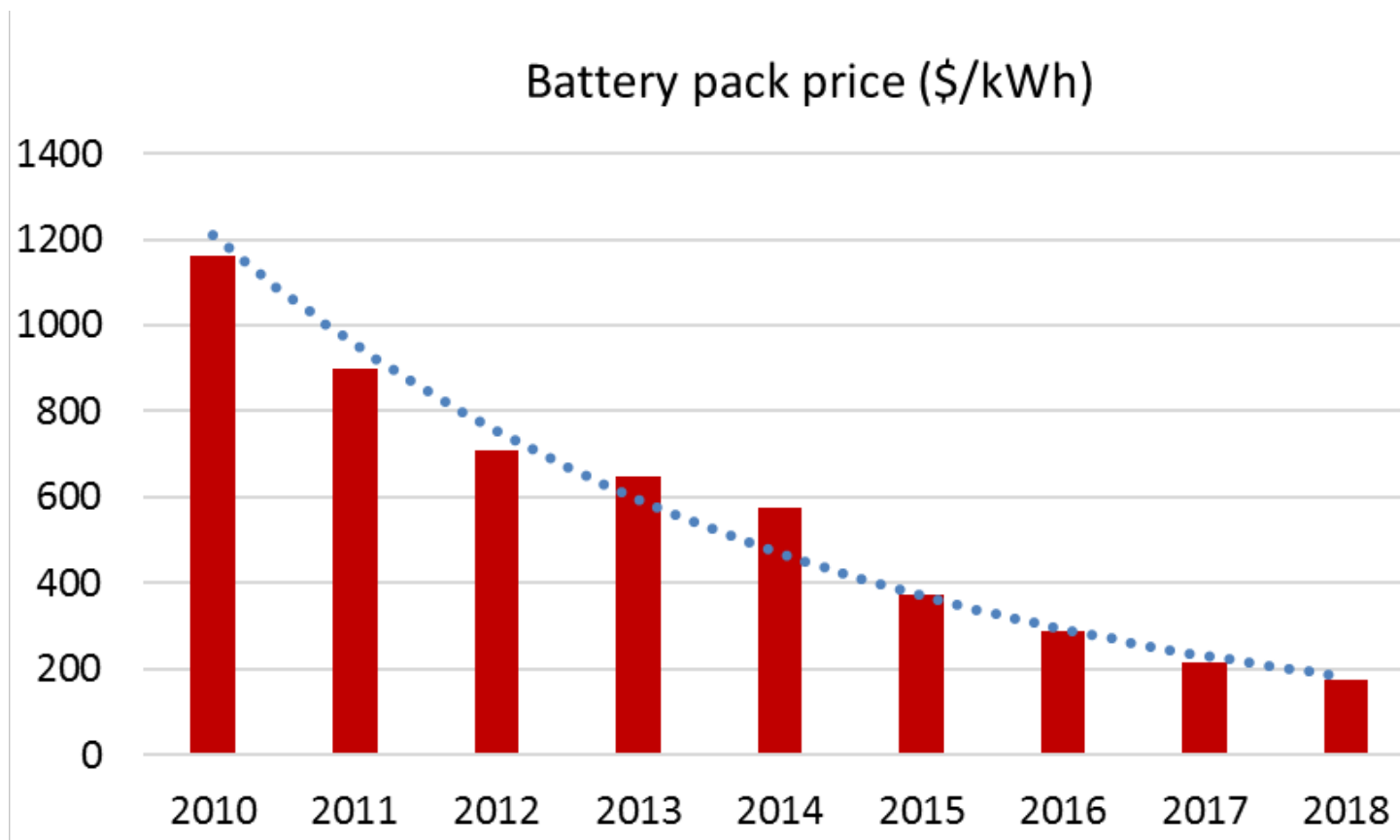

Scenario for development of investment costs

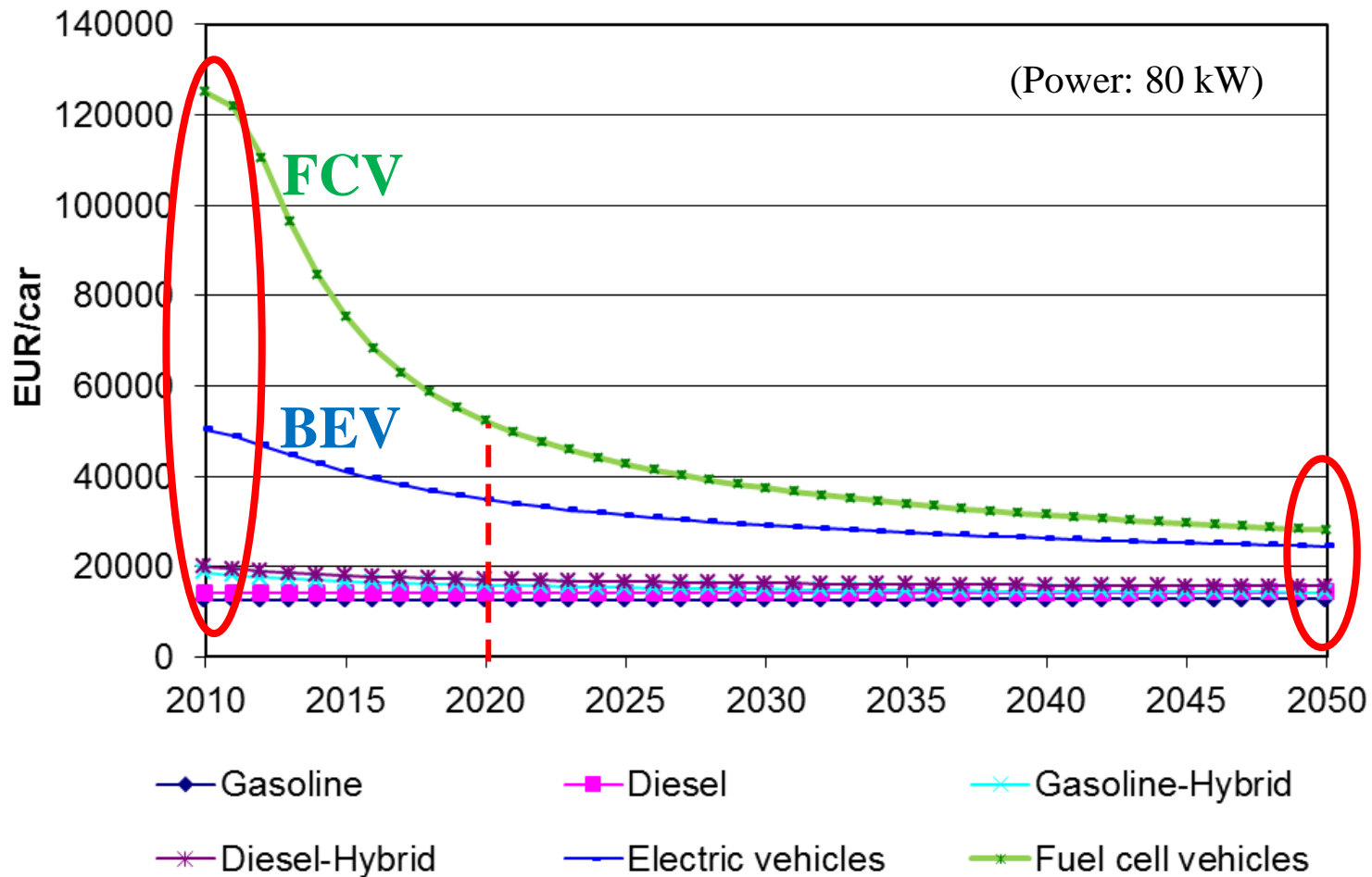

Costs of mobility – 2050

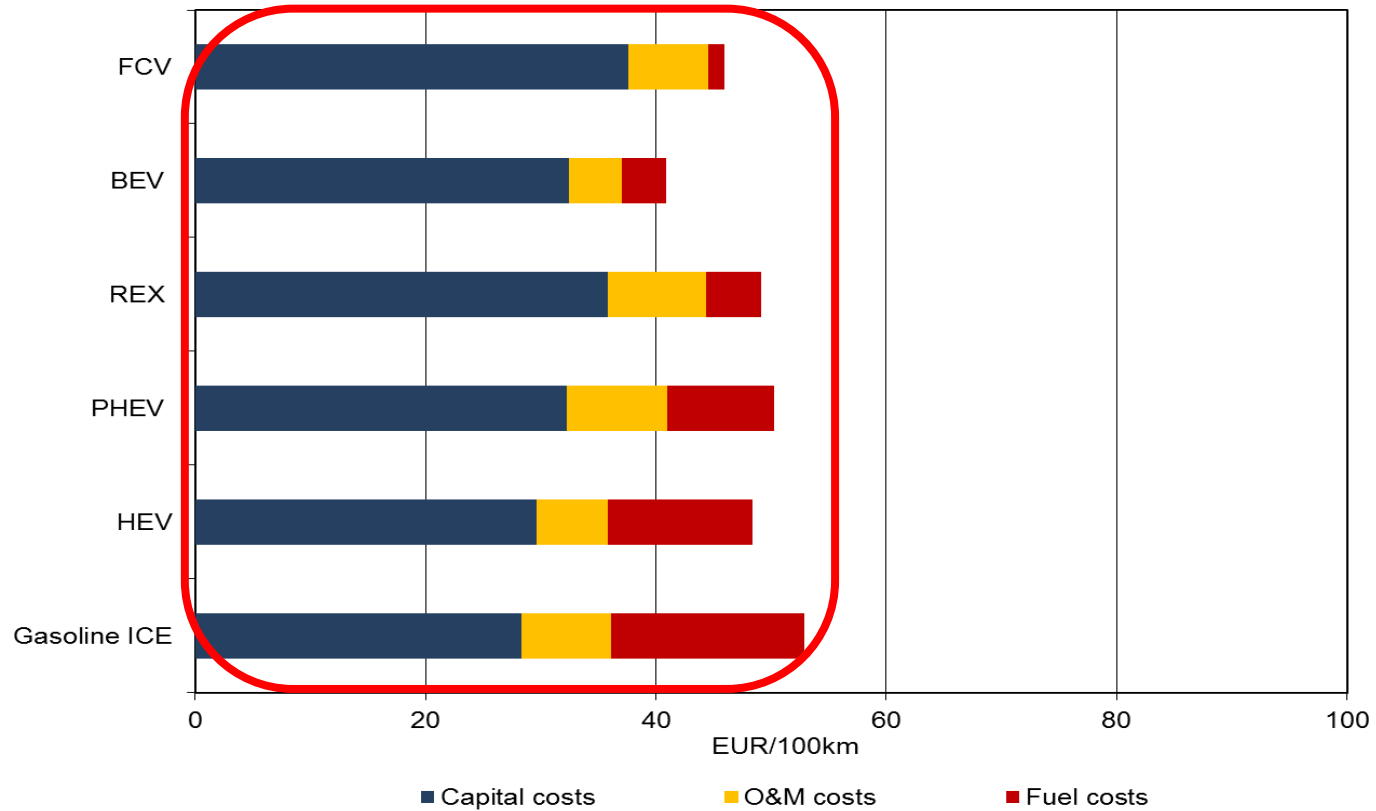

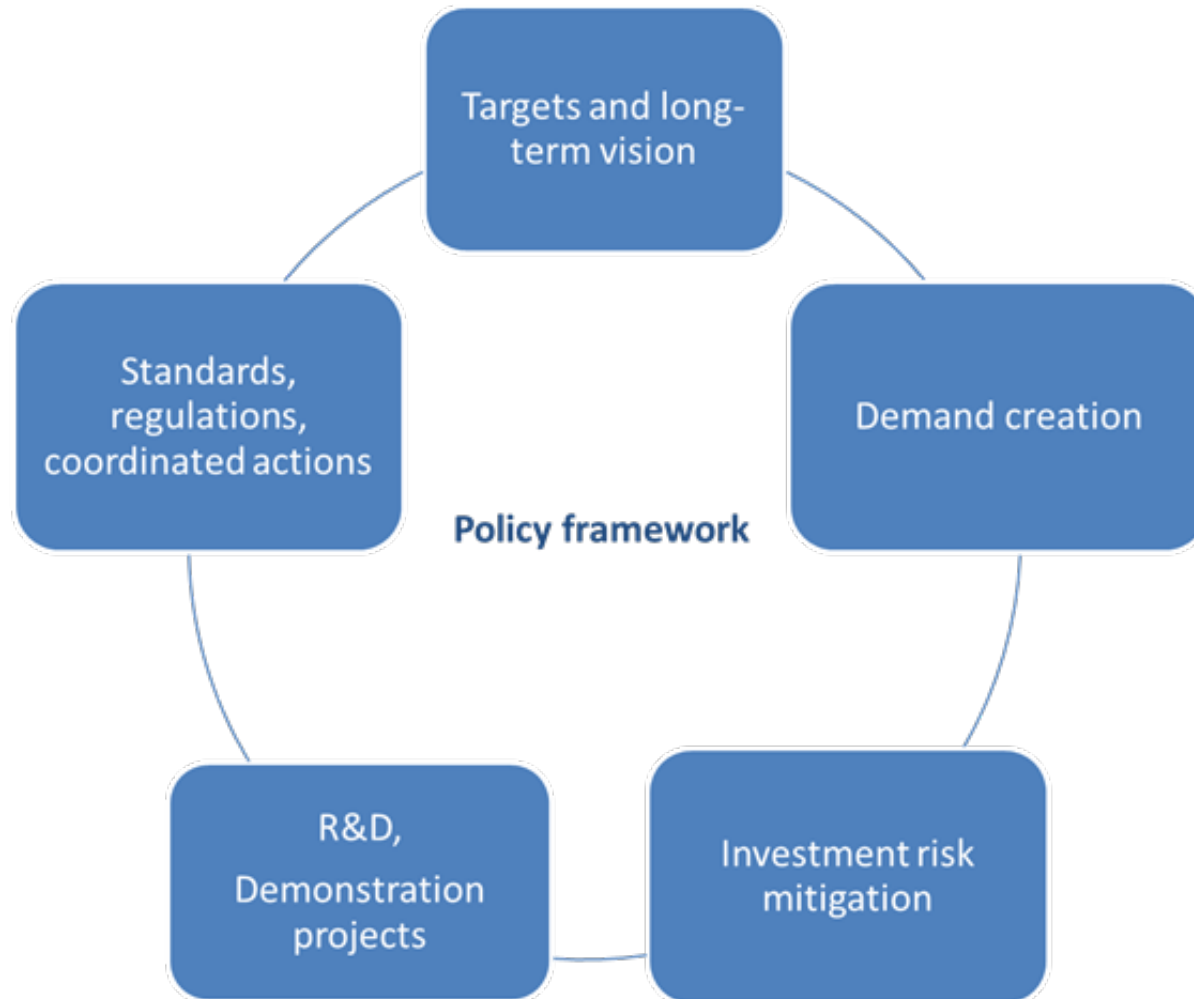

- Energy efficiency
- Refuelling time
- Driving range
- Weight of energy storage

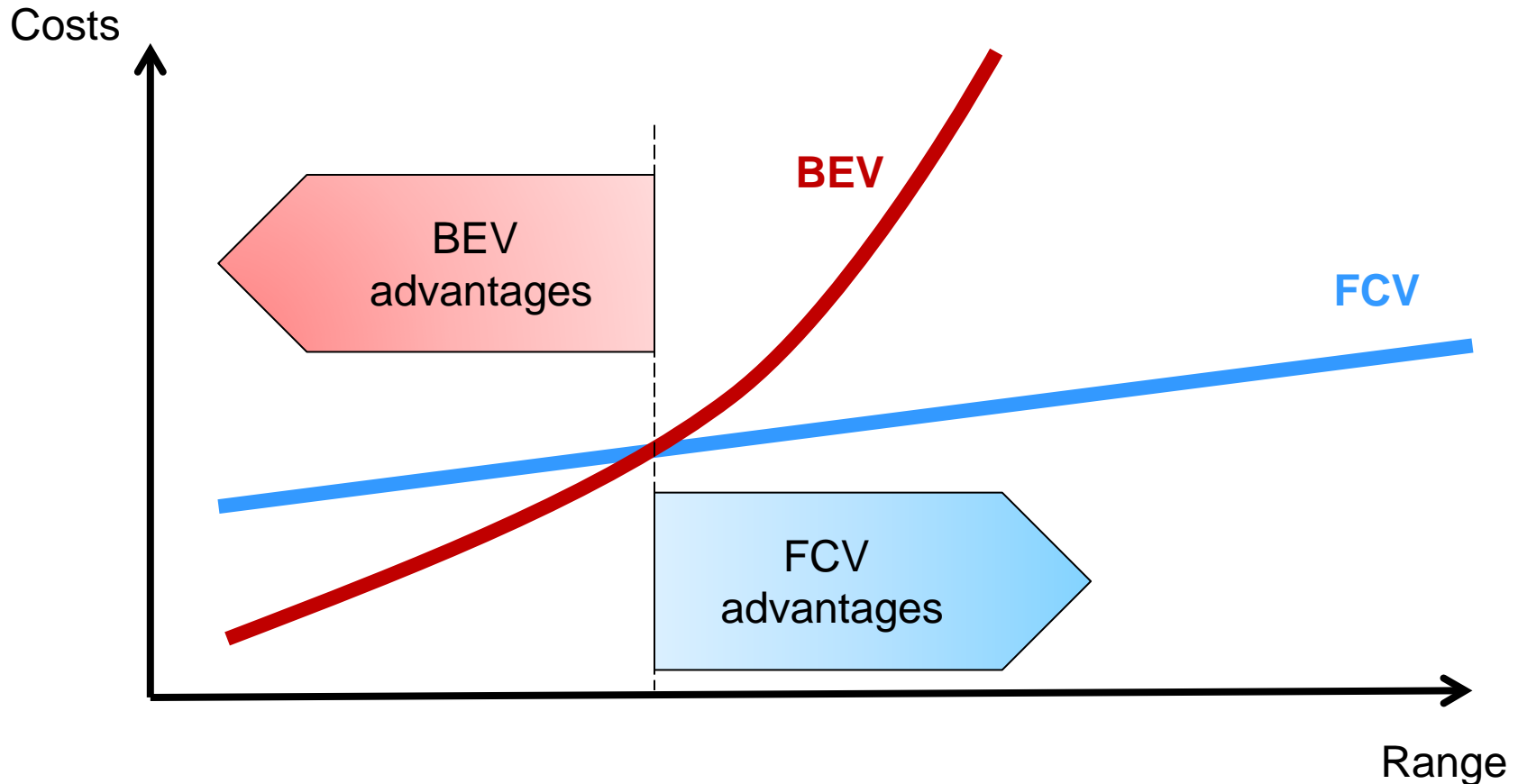

Announced Hydrogen Council vision for FCV

2019

~ 25000 FCVs
(incl. cars, buses and trucks)

2030

10-15 mil. cars; 0.5 mil. trucks

✓ 11 March 2020 – global pandemic

✓ Partial or total
lockdowns....55% of the
global population....60% of
global GDP

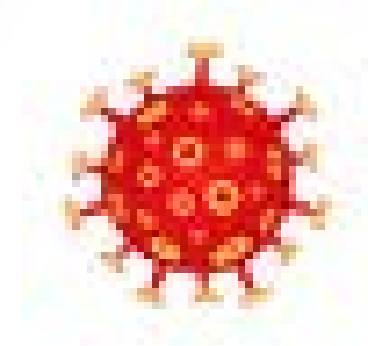
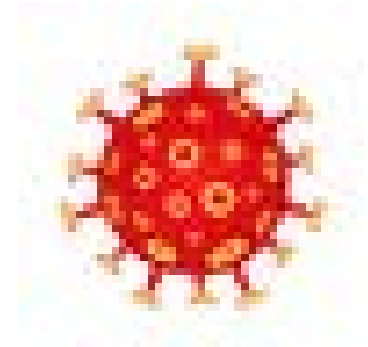
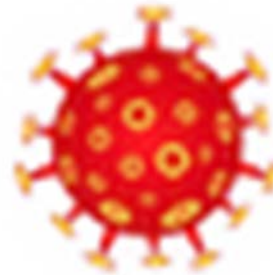

Global annual change in real gross domestic product (GDP), 1900-2020

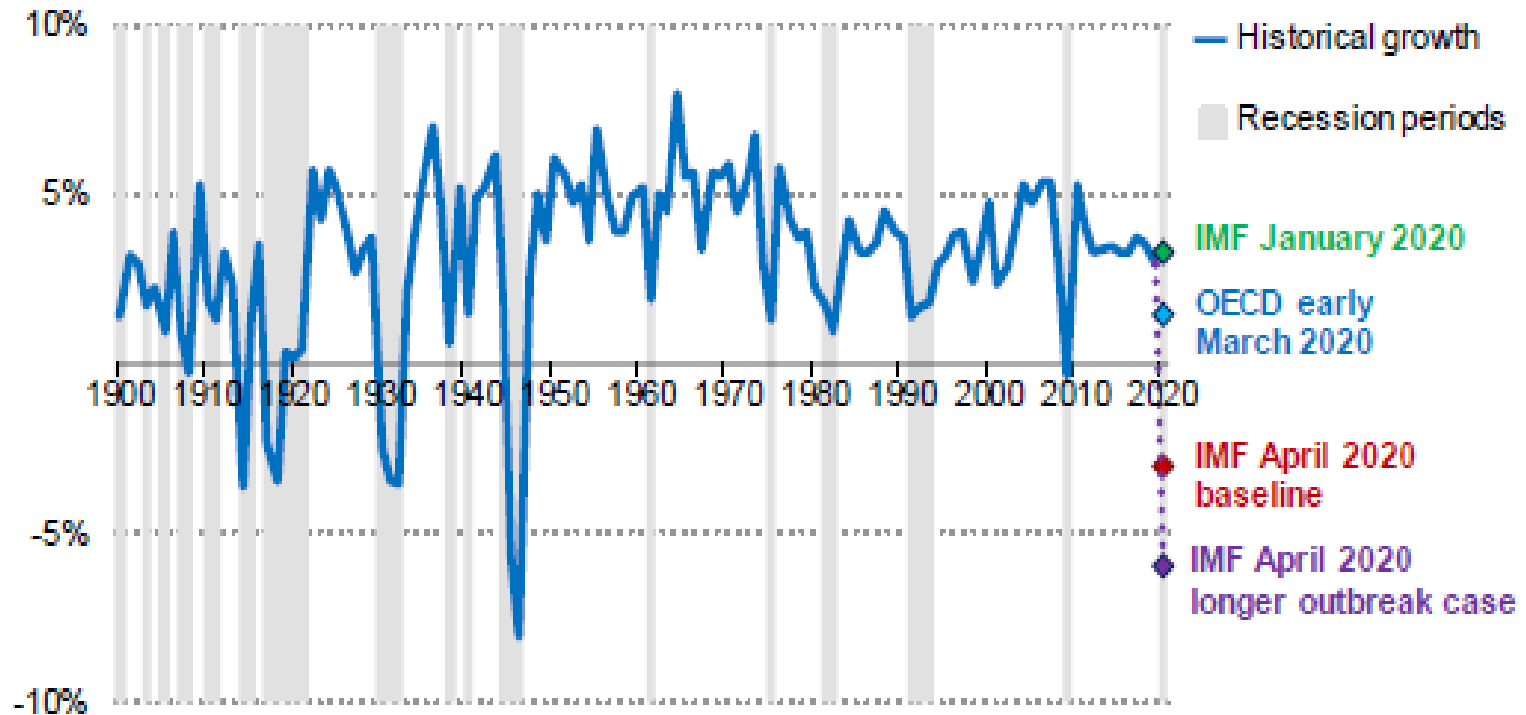

IEA 2020. All rights reserved.

Sources: IEA based on IMF World Economic Outlook (January and April 2020), OECD Interim Economic Outlook Forecasts (March 2020) and Maddison Project Database (2018).

Car sales decline in selected countries
(January and February 2020)

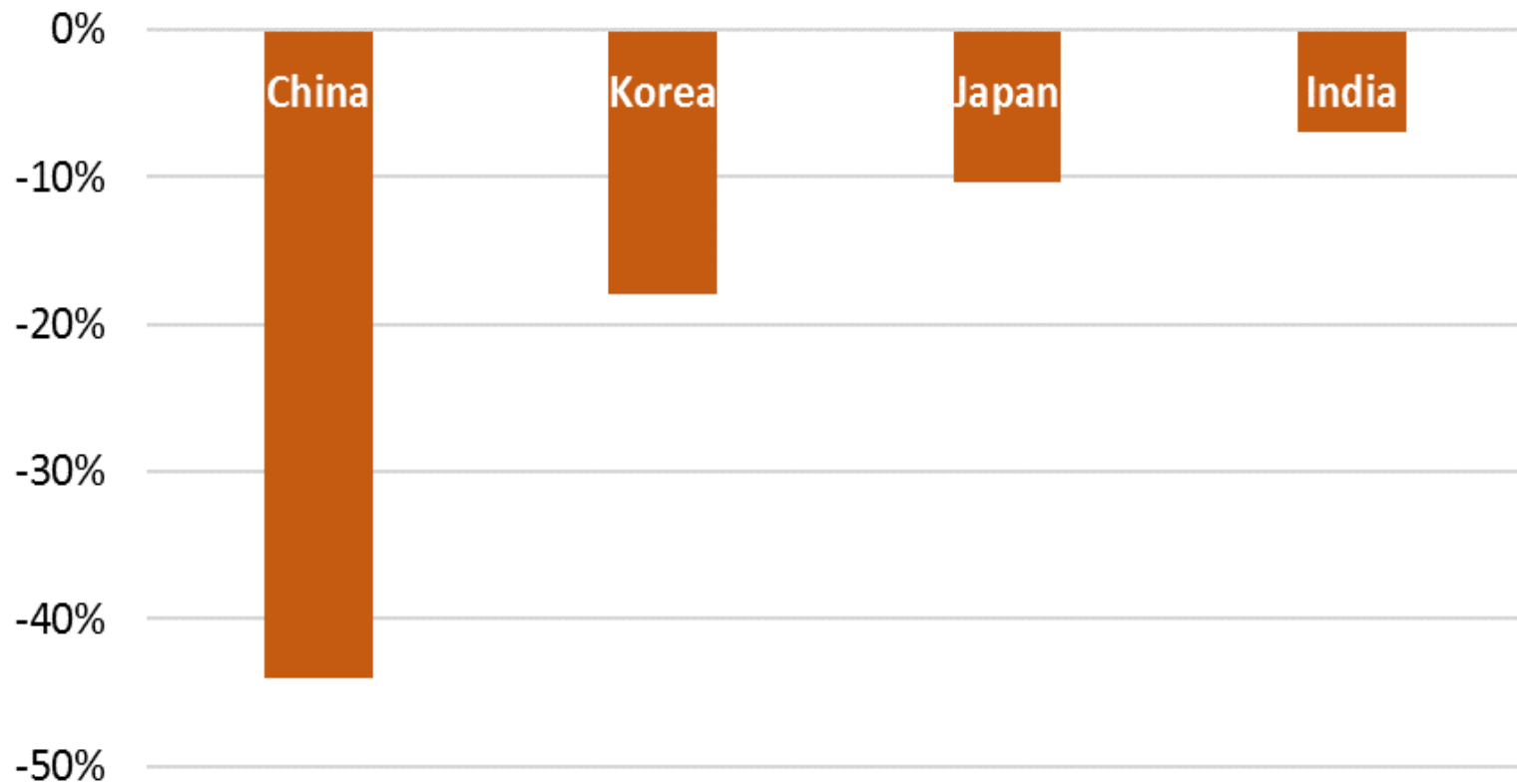

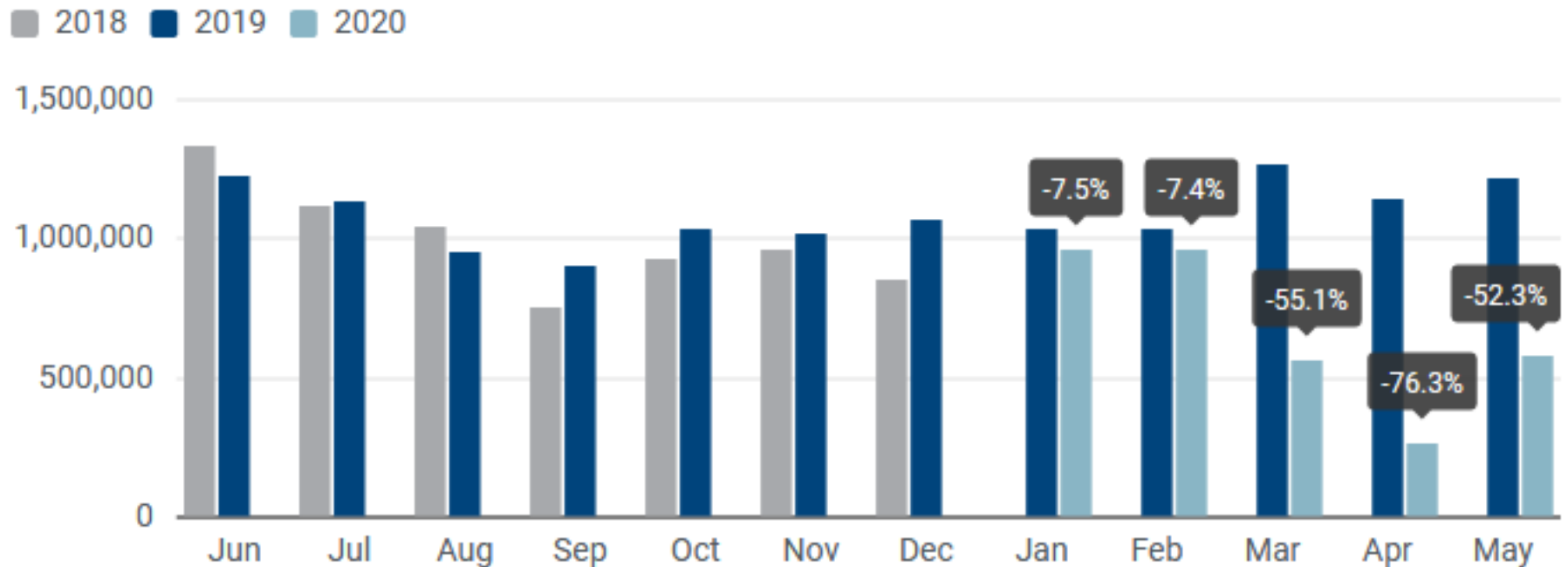

Created with LocalFocus

Source: ACEA

From January to May 2020, EU demand for new passenger cars contracted by 41.5%.

- ✓ China: EV sales dropped 54% by the end of January, 90% by the end of February
- ✓ Oil price drop
- ✓ Driving range

Short-term environmental benefits

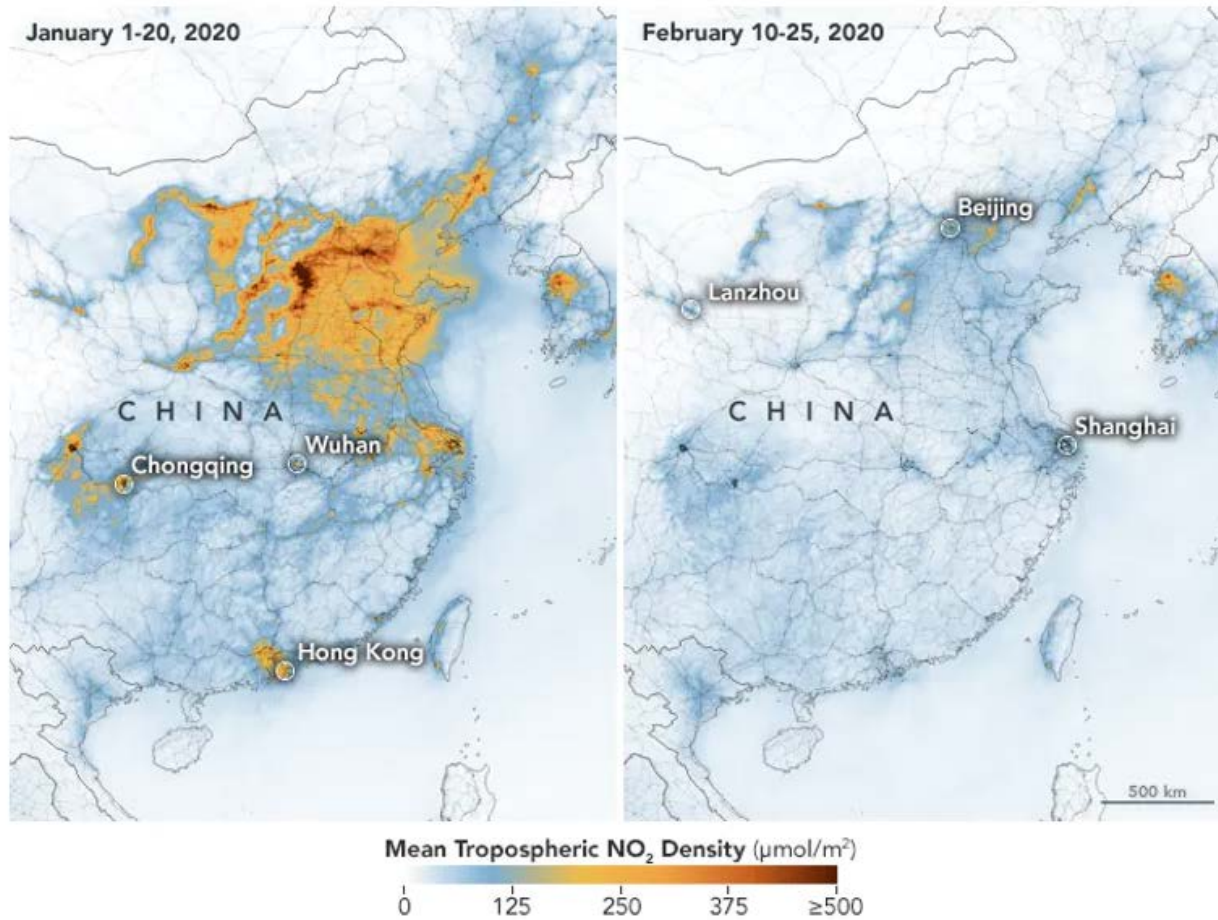

As new daily cases of COVID-19 reached their peak in China, air pollution plummeted. ESA/NASA, Author provided

- ✓ EVs...full environmental benefit ...electricity from RES
- ✓ Future policy design should ensure high environmental benefits of EVs
- ✓ High uncertainties regarding the long-term impacts of COVID-19 ...transport demand will be reduced...increasing role of home-working, decrease of international travel...
- ✓ Lower investment in electric vehicles
- ✓ ...unique opportunity to rethink the transport system

ajanovic@eeg.tuwien.ac.at